



Atlan[®]
STORMWATER

Floating Treatment Wetlands

Biomimetic modules for environmentally-sound
& sustainable stormwater treatment



Supercharged Pollutant Removal

Exposed plant roots in the water column create a network of natural, biological stormwater treatment pathways. Providing increased surface area for biofilm growth, these microorganism hotspots drive sedimentation, nitrification, and reduce algal blooms.



Robust Riverway Performance

Meeting the demands of your project's community, climate and water conditions, our Floating Wetlands are designed with custom anchoring to meet the demands of your waterways – with extensive testing in areas subject to wave chop, water movement, wind loading and boating use.



Modular & Scalable Design

Modular systems allow for easy customization and expansion based on water body size and treatment needs. Effective for municipal, industrial, and agricultural wastewater treatment.



Zero Land Use

Floating Wetlands occupy smaller site footprints and are designed for placement on open water bodies – improving land usability, community access and lot yield. Provides resilience against flooding and erosion.



Biomimicry of Natural Floating Islands

Biomimetic treatment asset that mirror the natural ecology of floating islands and provide the nutrient absorption and stormwater pollution removal capabilities of wetlands environments.



Improving Land Value

Constructed stormwater wetlands enhances waterfront beautification, amenity and water quality programs. Lifting property value and livability, these green assets protect our waterways and can be retrofitted in existing ponds, lakes and streams.



Habitats for Local Fauna & Flora

Providing floating island habitats for local species, such as frogs, birds, turtles and fish, floating wetlands allow wildlife and plants to thrive. Mirroring natural wetlands, they can be customized with native plant selections and local flora to support biodiversity.



Sustainable Waterways

Floating Wetlands mimic natural green ecosystems – with minimal environmental impacts. They require no power to operate, the manufacturing process is low-energy, and the plants are eco-sourced to harmonize with natural vegetation. Helps mitigate climate change by capturing carbon dioxide through plant growth.



Plant Density

Recommended planting density is three to five plants per ten square feet with species selected for their buoyancy and superior root structures offering an increased surface area. Popular options include terrestrial species such as wetland sedges, rushes and grasses.



The Atlan Floating Treatment Wetlands are an innovative, nature-based water treatment solution designed to improve water quality by mimicking natural wetlands.

These floating platforms support aquatic plants whose roots extend into the water, absorbing pollutants such as nitrates, phosphates, heavy metals, and organic matter. Beneficial microbes colonize the plant roots, further enhancing pollutant breakdown and nutrient removal.

Made from durable, eco-friendly, and buoyant materials, Floating Wetlands are modular and scalable, making them adaptable for various water bodies, including lakes, rivers, reservoirs, ponds, and stormwater basins. They help control algae blooms, enhance dissolved oxygen levels, and provide habitat for fish, birds, and other aquatic life. Additionally, they contribute to climate resilience by sequestering carbon, preventing erosion, and reducing the impact of flooding.

Applications

- Municipal wastewater treatment
- Treatment of stormwater runoff
- Industrial wastewater treatment
- Stream and lake restoration
- Beautification of community facilities
- Golf courses or facilities that utilize treated wastewater effluent

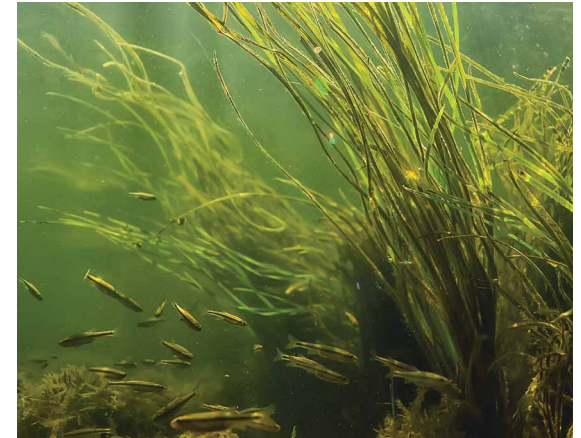

In stormwater applications, the installation of Floating Wetlands into inlet zones or detention lagoons greatly enhances the stormwater cleaning process by removing:

- Total suspended solids
- Nutrients
- Gross pollutants
- Heavy metals
- Fine colloidal and particulates

Independently tested and validated, these systems provide high-rate performance in both average flow and storm events. Truly environmentally sound and sustainable, Floating Wetlands have a dramatic effect on:

- Anaerobic digestion
- Odor mitigation
- Nitrification processes
- Denitrification and polishing
- Biochemical oxygen demand
- Removal of TSS
- Reduction in fecal coliforms
- Reduction in phosphorus

Floating Wetlands Pollutant Removal Mechanisms

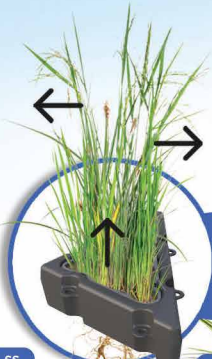

Nutrients and metals >>> uptake by plant

- SS
- Cu
- Pb
- Me
- TN
- Cd
- NH₂⁻
- As
- Drugs
- Cr
- Pathogens
- TP
- COO



Micropollutants >>> broken down by biofilm

BETTER WATER QUALITY

- SS
- Pb
- Cd
- NH₂⁻
- COO
- As
- Cu
- Hg
- Me
- TN
- TP
- Cr
- Drugs
- Pathogens

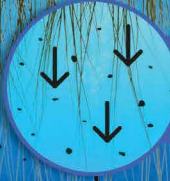

Suspended Solids (TSS) >>> filter and slough off



thrive and form biofilms that continuously clean the water by reducing total suspended solids and biochemical oxygen demand.

Advanced Modular Biological System

Developed with leading international scientists, Atlan FTWs represent a breakthrough in water treatment technology. The modular design allows for flexible installation in various sizes and configurations. Each floating module measures approximately 34 in (858mm) x 34 in (858mm) and can be connected using patented locking pins to cover larger areas. This staged installation approach is ideal for projects with budget constraints, allowing for gradual expansion to meet future wastewater treatment needs.



Plant Selection for Maximum Efficiency

The plant species used in Atlan FTWs are carefully selected to suit the project's specific environment. They include a mix of wetland species from the sedge, grass and rush families, suited for both freshwater and brackish conditions.

We recommend the use of native plants as approved by your local state or provincial conservation authority.



Anchoring and Tethering for Stability

Each floating wetland system is securely anchored to prevent unwanted movement while still allowing for vertical flexibility. This ensures the wetlands can rise and fall with the tide or changes in water levels, maintaining consistent contact with the water surface for optimal performance.

The anchoring and tethering solutions are customized based on local site conditions and may include platypus ground anchors, plow anchors, concrete blocks and fixed bank anchor points.

With its scientifically proven effectiveness, Atlan Floating Treatment Wetlands offer a sustainable, adaptable, and high-performance solution for restoring and maintaining healthy aquatic ecosystems.

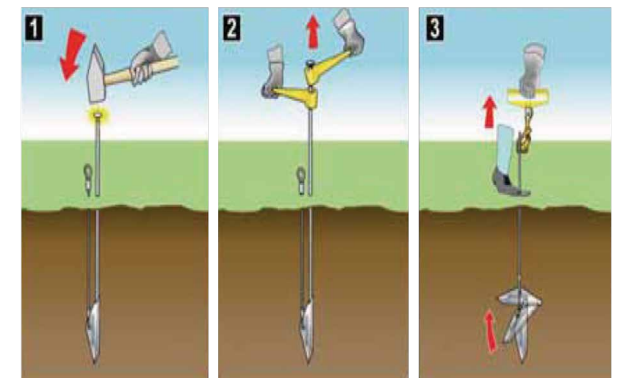

DRIVING THE ANCHOR

REMOVING THE RODS

LOADLOCKING/ SETTING

How Does It Work?

Atlan Floating Treatment Wetlands (FTWs) provide an innovative, nature-based solution for improving water quality in a variety of aquatic environments. By mimicking natural wetlands, they create a fertile base for plant growth while facilitating bioremediation—where microbes and bacteria break down pollutants.

Bio-Remediation Through Plant Roots

As plants grow on the floating wetland modules, their roots extend downward through the wetland media, creating an extensive surface area for microbial activity. These microbes and bacteria, which do not swim, attach themselves to the fibrous root structures and the wetland's biofilm. Within this biofilm, they trap and digest organic matter, odors, and excess nutrients such as nitrogen and phosphorus, effectively purifying stormwater and wastewater.

Maximizing Pollutant Removal

The floating wetland modules create a dense root mass beneath the water's surface, with varying root densities. This variation enhances the interaction between water and biofilm, increasing the efficiency of pollutant breakdown. The microbial colonies secrete sticky extracellular proteins, allowing them to

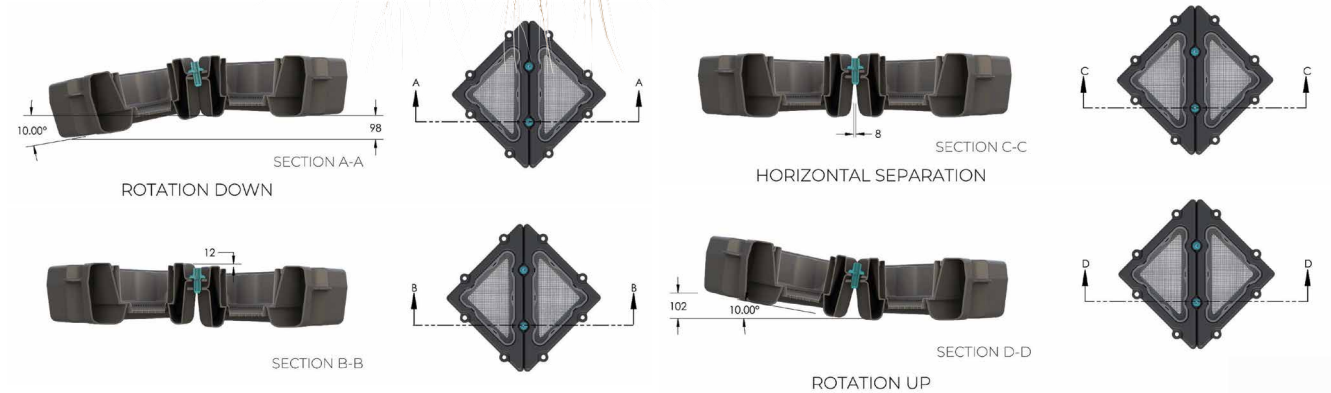
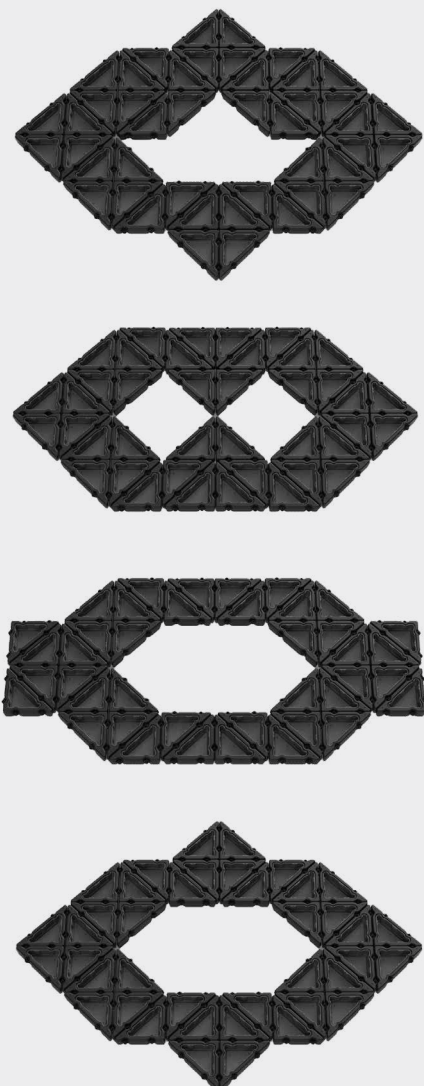

Wind and Wave Movement Modelling

The Floating Wetlands have been modelled and tested to be installed in areas subject to wave chop and water movement mixed with wind loads. They are constructed with significant allowance for movement and flex, thus making them suitable for installations in areas exposed to boat and wave movement.

Customizable Solutions

Floating Treatment Wetlands are available in a range of customizable solutions from size, shapes, functionality and environmental capabilities. Our experienced team is available to guide you through the design process and can work with you to achieve your project goals.

TRIANGLE MODULE DESIGN DATA

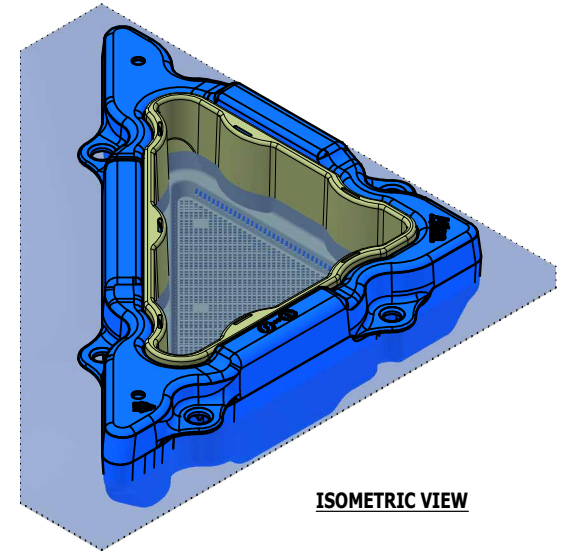
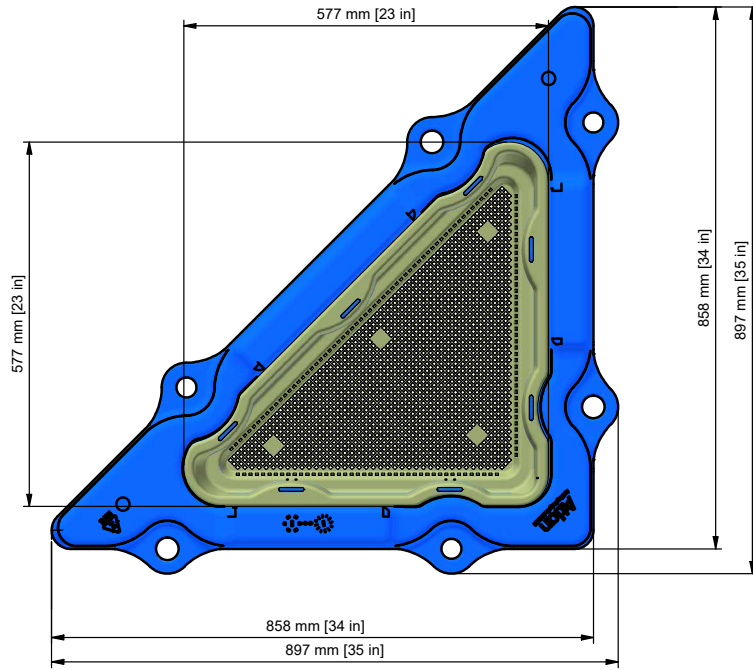

ISOMETRIC VIEW

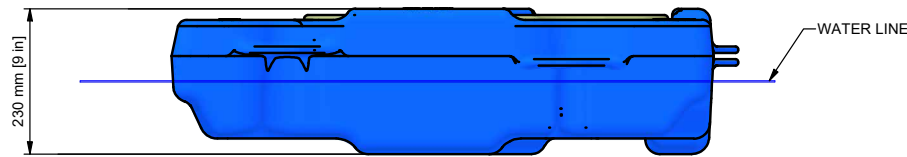

TOLERANCE: All Dimensions to Closest 10 mm & +/- 30 mm | **ALL INTERCONNECTING PIPEWORK, PITS AND ASSOCIATED DRAINAGE BY OTHERS**

CLIENT:		CONFIDENTIAL - The drawings must not be disclosed to any third parties without written permission from ATLAN STORMWATER. Unauthorized disclosure may result in prosecution.	
INITIAL RELEASE		© ATLAN STORMWATER - This drawing is the property of ATLAN STORMWATER ABN: 93 151 832 629 and is subject to return on demand. It is submitted for the use only in connection with the proposal and contracts of ATLAN STORMWATER with the expressed conditions that it is not to be reproduced or copied in any form. This data must only be used in accordance with our standard terms and conditions.	
1	7/07/2024	P.Z.	© Copyright ATLAN STORMWATER accepts no responsibility for any loss or damage resulting from any person acting on this information. The details and dimensions contained in this document may change, please check with ATLAN STORMWATER for confirmation of current specifications.
REV	DATE	BY	DESCRIPTION
			CHK

Drawn	Date		
P.Z.	1/07/2024		
Check	Date		
Verified	Date		
Approved	Date		
Request No.		PROJECT	
		TITLE	
		WETLANDS TRIANGLE MODULE	
		MESH-004_FLOAT_20210929	
		MESH-003_TRAY_20210929	
		DESIGN DATA SHEET	
SCALE	SIZE	SHEET	REV
N.T.S.	A3	1	1
CUSTOMER CODE :		DWG No.	
		240701.P.01.GA	

C:\Users\Phillip\OneDrive\Documents\Water\Designs\ATLAND1 - STANDARDS\AQUASCAPES\AQUASCAPES\MODULE - INFORMATION\DRAWING\240701.P.01.GA.dwg

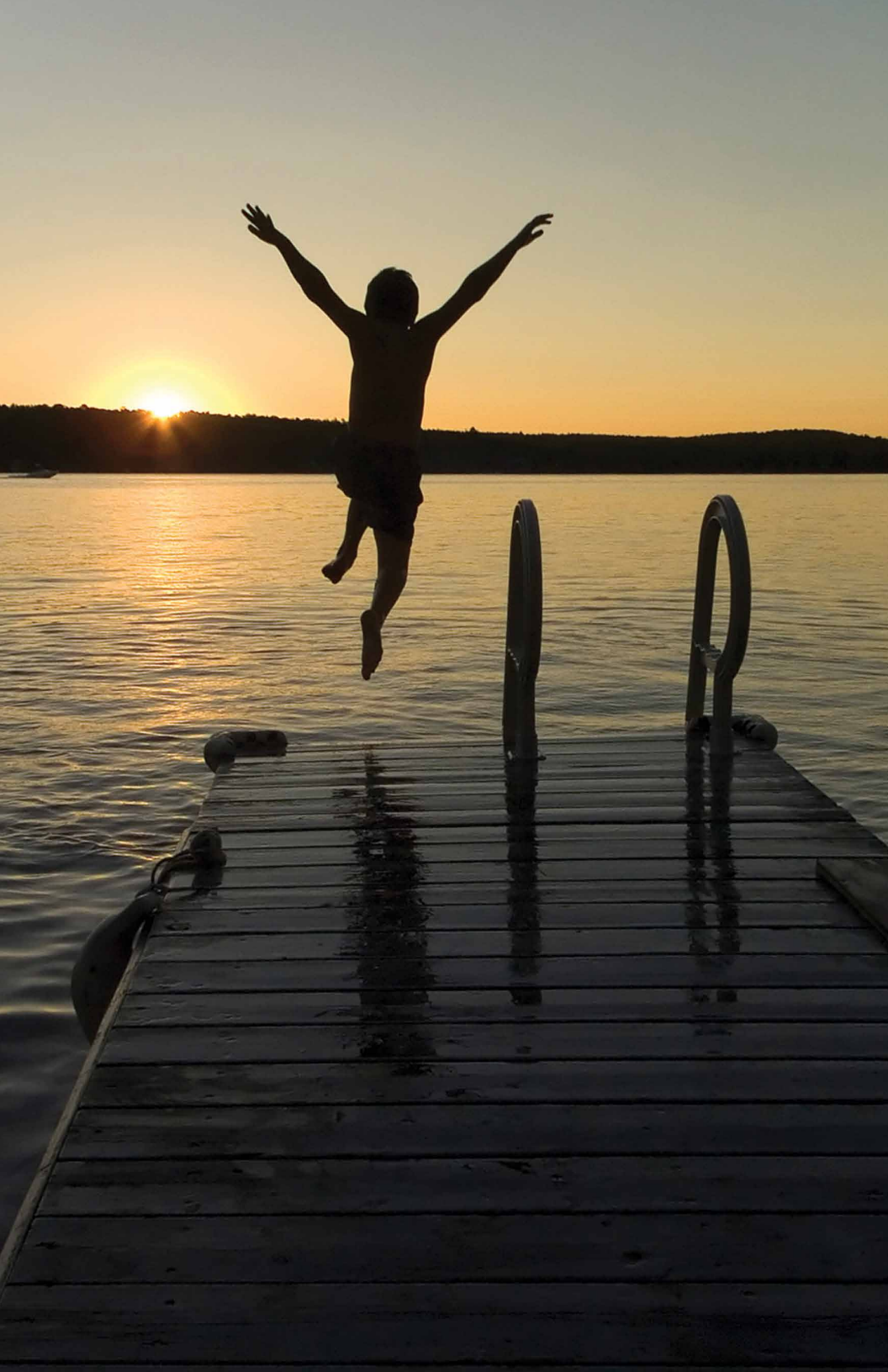

Joy in water

'We believe clean waterways are a right, not a privilege and we work to ensure a Joy in Water experience for you, with your family & friends.'

Andy Hornbuckle, CEO

Atlan[®]
STORMWATER

USA

P 918 931 0757

sales@atlanstormwater.com | atlanstormwater.com

AUSTRALIA

P 1300 773 500 | +61 2 8705 0255

sales@atlan.com.au | atlan.com.au

NEW ZEALAND

P 09 930 7417

sales@atlan.co.nz | atlan.co.nz

INTERNATIONAL

atlanstormwater.com